



S4A

2011-2019 Ford PIU Instructions

Thank you for purchasing CargoRAXX. See attached assembly and installation instructions. Please insert L-brackets along the sides of the floor prior to inserting the finished unit into the vehicle and line them up where you would want the front leg. Feel free to reach out with any questions. My direct line is 732-708-0077.

Best,

Roman Lesko
CargoRAXX

For feedback or questions, contact:

sales@cargoraxx.com

1-844-867-RAXX

For feedback or questions, contact:

sales@cargoraxx.com

1-844-867-RAXX



ASSEMBLY GUIDE

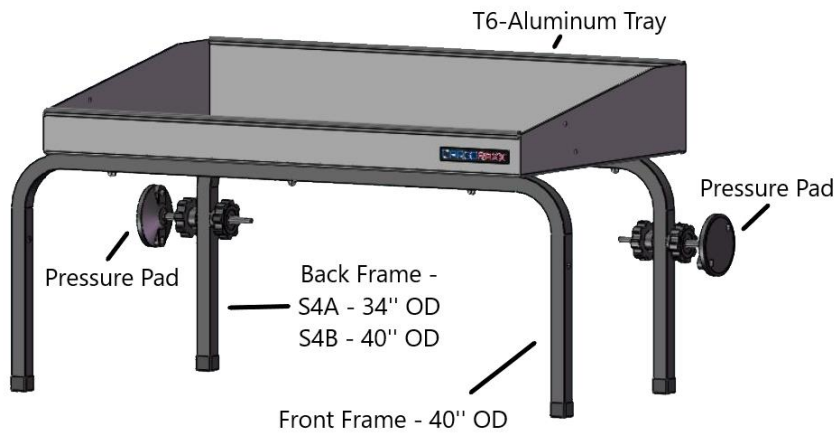

CargoRAXX S4A and S4B

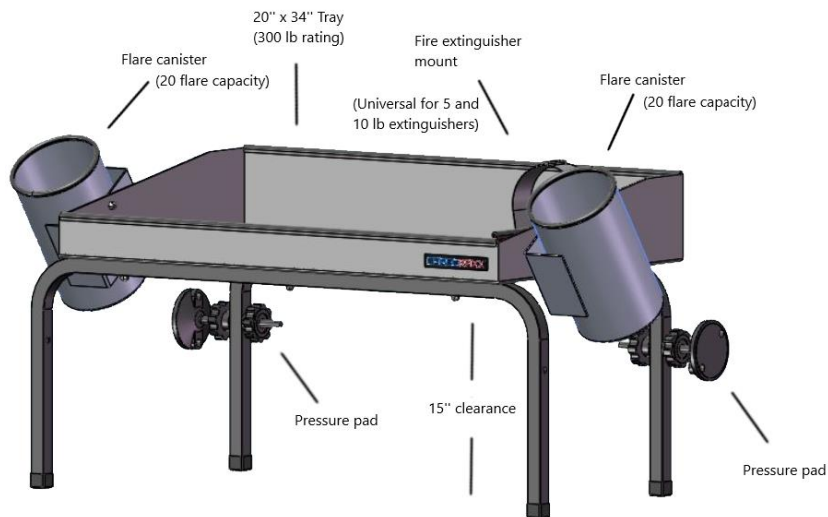

CargoRAXX S4B Fully Loaded -
2020 Ford Police Interceptor Utility

For feedback or questions, contact:

sales@cargoraxx.com

1-844-867-RAXX

Leg Breakdown

S4A

Ford Police Interceptor
Utility (2011-2019)

Dodge Durango (2011-
2020)

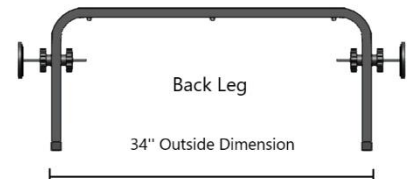
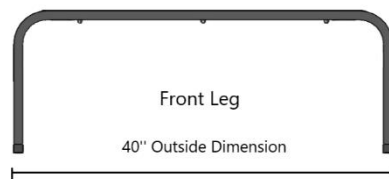
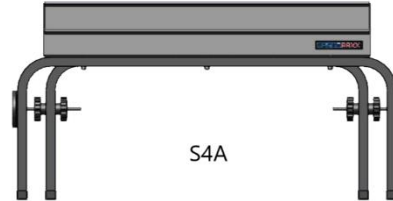

S4B

Ford Police Interceptor
Utility (2020)

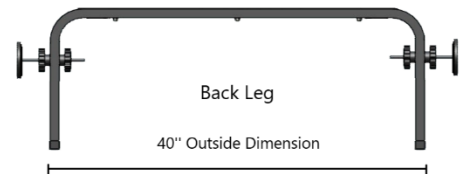
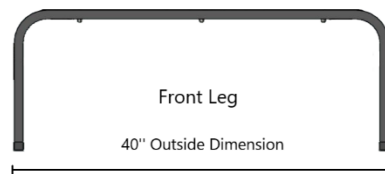
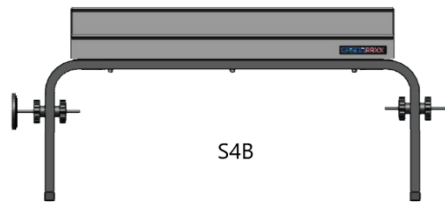

For feedback or questions, contact:

sales@cargoraxx.com

1-844-867-RAXX

S3A

Chevy Tahoe

Ford Expedition

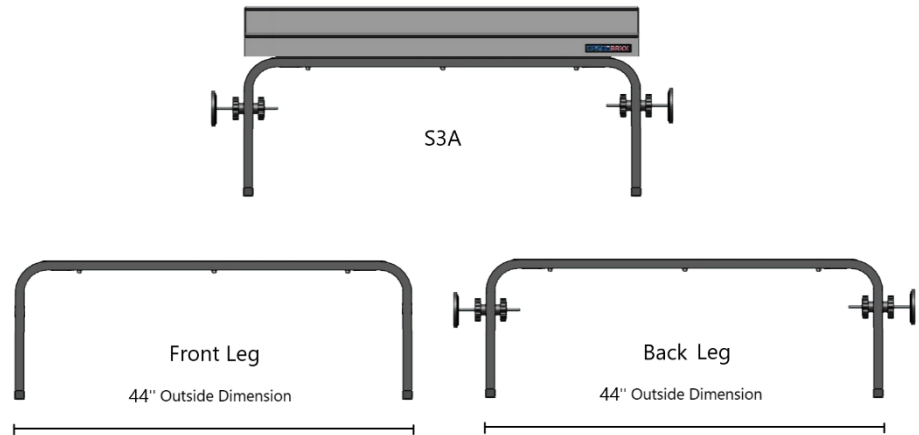

Assembly Kit

For feedback or questions, contact:

sales@cargoraxx.com

1-844-867-RAXX

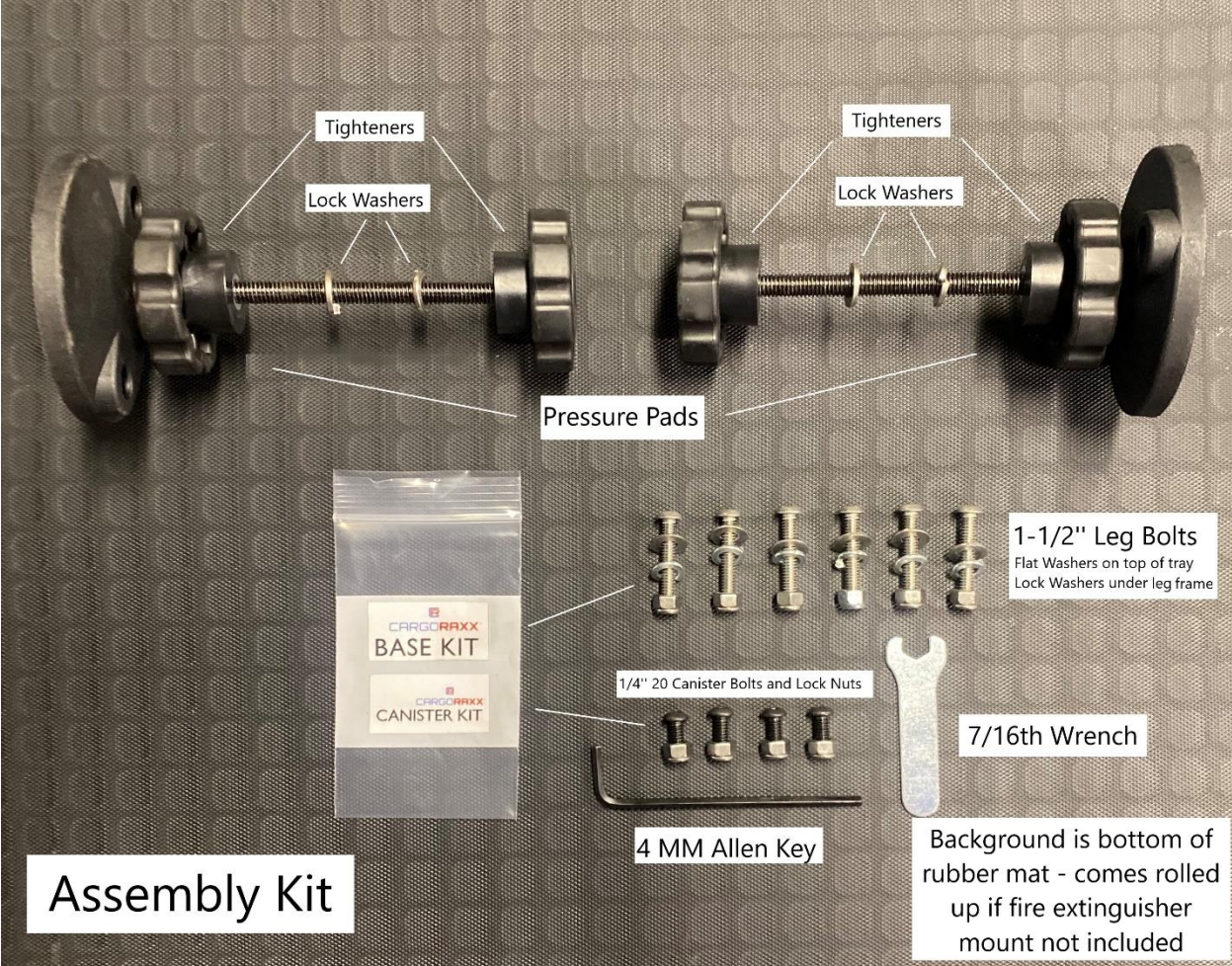

STEP 1

For feedback or questions, contact:
sales@cargoraxx.com
1-844-867-RAXX

Install front and back legs onto tray using our six (6) 1-1/2" bolts – 3 for the front leg and 3 for the back leg. Make sure to install with **flat washer in tray and lock washer on the bottom of the leg frame.**

Use a 4 mm allen key and 7/16th wrench to secure (both included in kit).



6 total bolts to install (3 in the front and 3 in back)

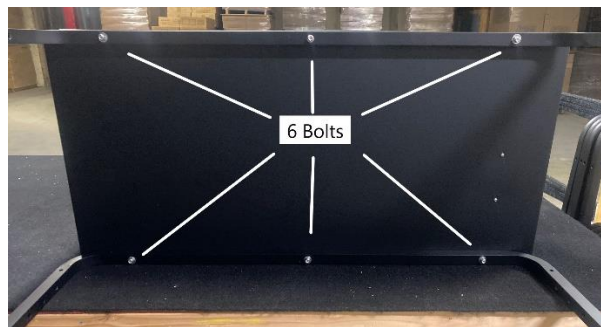

STEP 2

For feedback or questions, contact:

sales@cargoraxx.com

1-844-867-RAXX

Place pressure pads through the hole of the back leg for S4A and S4B – make sure lock washers are between the fasteners and leg (see images on next page).

*Tahoe/Expedition model can have the pressure pads either on the front or back leg.

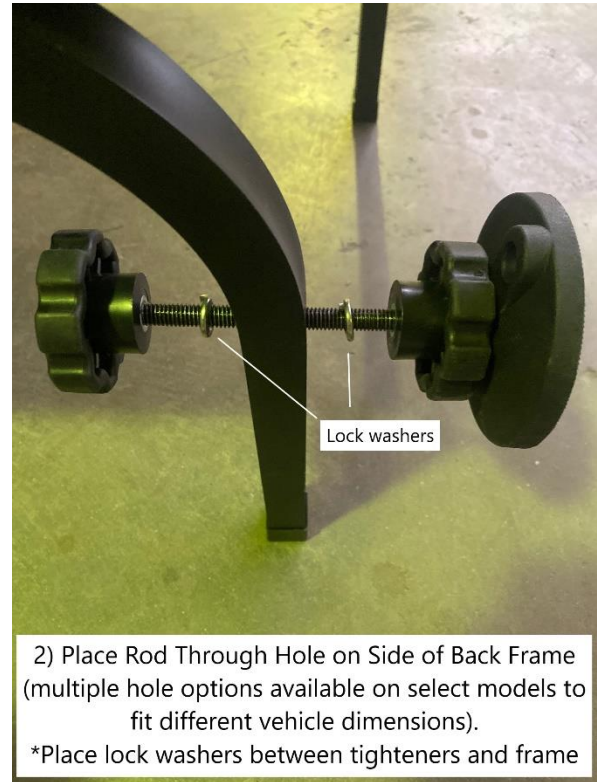

Lock washers to be located between tighteners and frame

*For Tahoes – we recommend bottom rear hole for pressure pads to align with side walls



For feedback or questions, contact:

sales@cargoraxx.com

1-844-867-RAXX

STEP 3

S4A Floor Bracket Installation Instructions

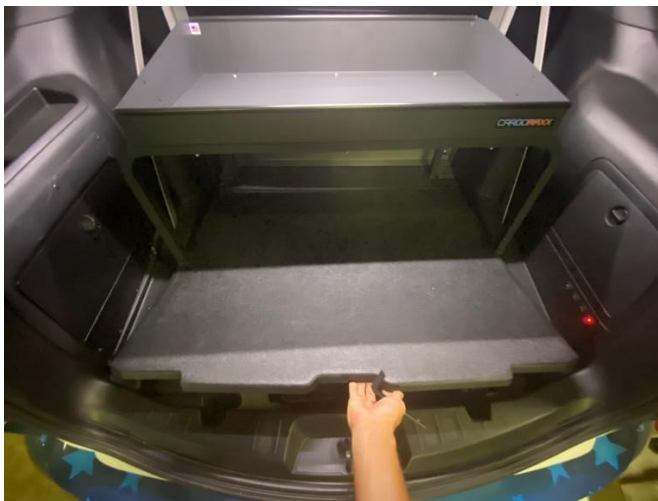

1 – Lift floor with rack loose on top (before tightening pressure pads).



2 – Insert L-brackets underneath and make sure it's pulled up against the bottom of the floor then align with front leg on rack.



3 - Once bracket aligned with front leg and desired pressure pad location, then insert hardware with nut on the outside to prevent a snag between the legs of the tray and tighten.

For feedback or questions, contact:

sales@cargoraxx.com

1-844-867-RAXX

Step 4

Position unit in vehicle against the back partition or as far back as possible and tighten pressure pads. If you pre-install canisters, you will have to go in at an angle:



For feedback or questions, contact:

sales@cargoraxx.com

1-844-867-RAXX

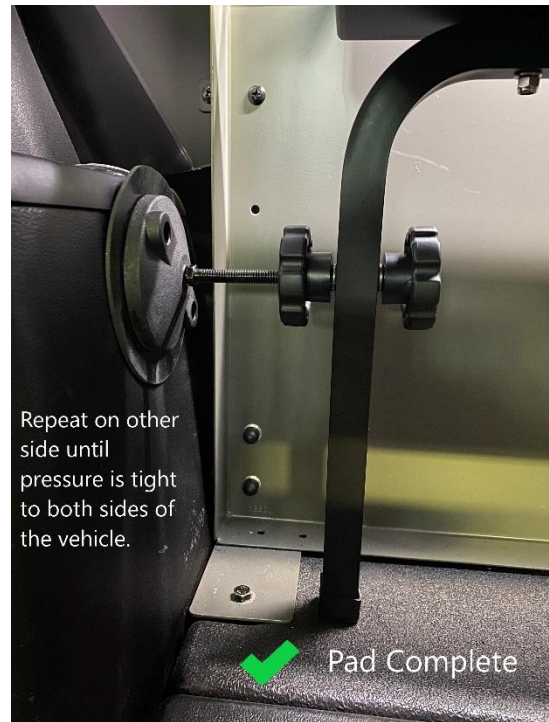

Step 5

Insert rubber mat – glossy side up

For feedback or questions, contact:

sales@cargoraxx.com

1-844-867-RAXX



Canister Installation

For feedback or questions, contact:

sales@cargoraxx.com

1-844-867-RAXX



1 – Insert bolts through holes from inside



2 - See holes for cylinders on the side of the tray



3 - Insert bolts into holes while securing from the inside

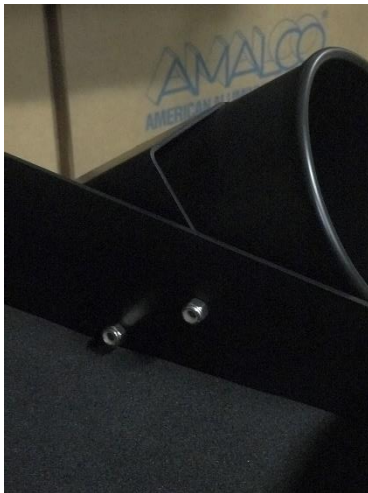

4 - Attach lock nuts



5 - Tighten the cylinder as much as possible with a 7/16 wrench and 4 mm allen wrench (included in kit)

Caution Tape Holder Installation

For feedback or questions, contact:

sales@cargoraxx.com

1-844-867-RAXX

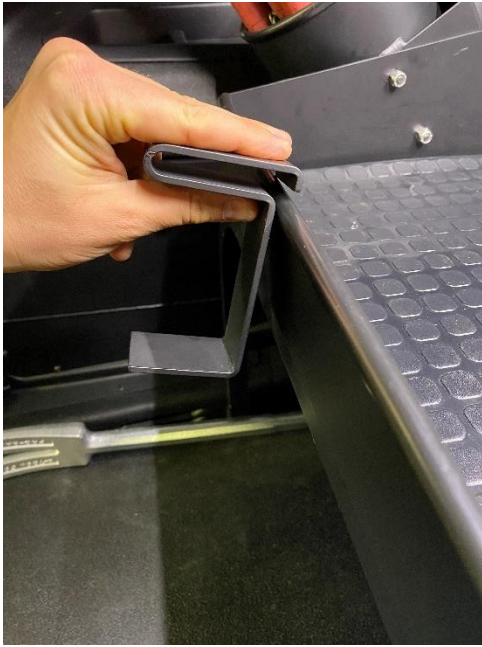

1 – Face caution tape holder down



2 – Snap the bend over the trim



3 – Press down with thumb to the final position as bend goes over the lip of the tray

For feedback or questions, contact:

sales@cargoraxx.com

1-844-867-RAXX

Halligan Mount Installation

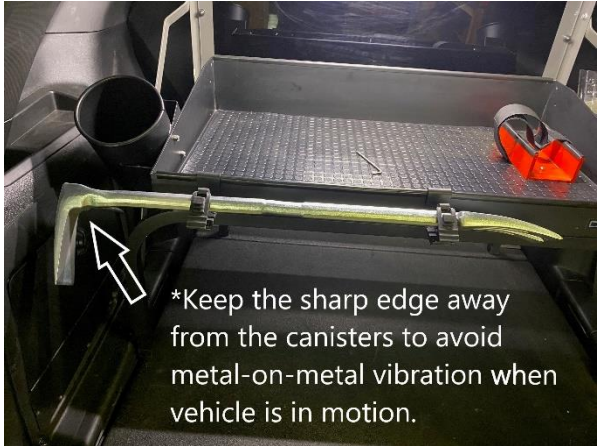

For feedback or questions, contact:
sales@cargoraxx.com
1-844-867-RAXX